

AIRRAID®

INTAKE SYSTEMS

#200-145 INSTALLATION INSTRUCTIONS

99-06 GM Full Size SUVs and Trucks/

2007 GMC Sierra "Classic" Truck W/ 4.8L, 5.3L, 6.0L

With Mechanical Cooling Fan and Low Profile Hood

Thank you for purchasing the Airaid Intake System. Please read the instruction manual carefully before proceeding with the installation. Contact Airaid @ (800) 498-6951 8:00 AM - 5:00 PM MST weekdays for questions regarding fit or instructions that are not clear to you. Your Airaid Intake System was carefully inspected and packaged. Check that no parts are missing, or were damaged during shipping. If any parts are missing, contact Airaid. The air filter element is protected from direct exposure to water and debris; care should be taken not to drive through deep water. WATER INGESTION IS THE DRIVERS RESPONSIBILITY! The air filter is reusable and should be cleaned using the Airaid Filter Tune-Up Kit periodically.

Thank you for selecting Airaid.



Packing List:

700-469	Airaid Premium Filter	1
KIT112MAFADA	Black MAF Adapter	1
KIT1121RRDAMC	Rear Air Dam Coated	1
KIT1121MAFDAC	MAF Panel Coated	1
KIT912T	Modular Intake Tube	1
KITHUMPHS02	Silicone Hump Hose	1
KITCOUPLER02	GM Coupler	1
KITWSTRIP02	Weather Strip 20'	1
KIT145HP	Hardware Pack	1
-KIT15DHC3050	1/4-20 x 1/2" SS Button Head Bolt	3
-KIT09FWZ019	1/4" Flat Washer	7
-KIT60C250HCS	M6-1x25 Hex Bolt	4

Packing List (cont'd):

-KIT6CNKEPZ	6-32 Keps Nut	5
-KIT6C31MXPPZ	6-32 x 5/16" Screw	5
-KIT6NWSAPZ	#6 Flat Washer	5
-KITHS56	#56 Hose Clamp	2

Tools Required for this Installation:

Flat Head & Phillips Screwdriver
10mm Socket or Wrench
5/16" Socket
Extension & Ratchet
5/32" Allen Wrench

Installation Instructions. Read Me!

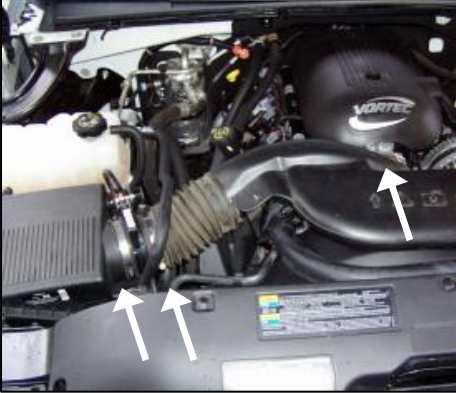

1. Disconnect negative battery cable. Loosen all three factory hose clamps located at the Mass Air Flow (MAF) meter and both ends of the factory intake tube.

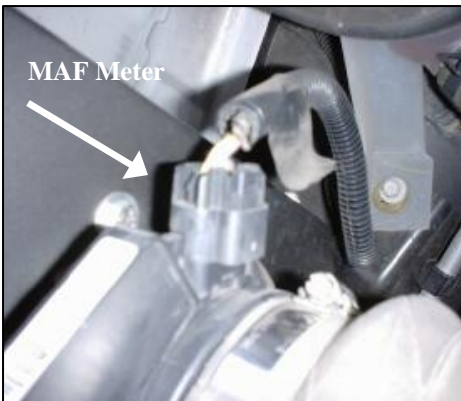

2. Unplug the MAF meter and remove the meter from the factory intake tube.



3. Using a flat head screwdriver, gently pry the radiator hose bracket from the factory intake tube assembly and remove the tube from vehicle.



4. Remove the factory air filter base and lid as an assembly. (Hint: pull straight up on the air filter base to remove, there are no bolts; just friction mounts).



5. Remove the five 10mm bolts that secure the factory air filter housing platform and remove the plate from the vehicle.

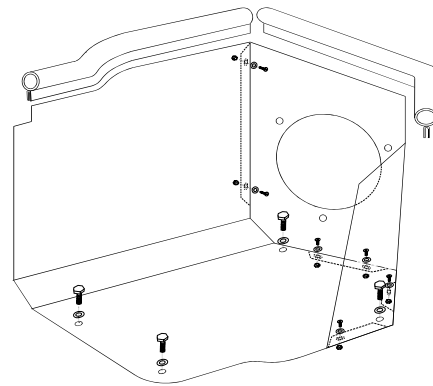

6. Position the two Airaid Cool Air Dam panels and fasten them together with the small #6 screws, nuts & washers provided.



7. Install the black plastic filter adapter using the three 1/4-20 x 1/2 button head bolts & three washers provided.

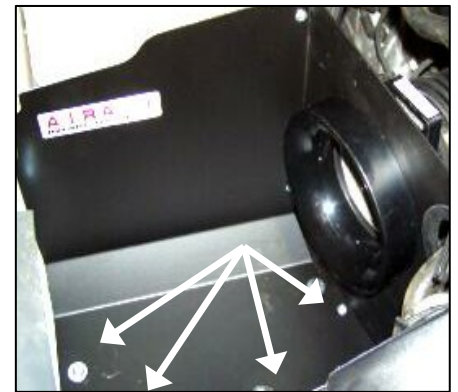

8. Position the Airaid Cool Air Dam Intake system in place of the factory air box & secure the Airaid system to the inner fender using the four supplied 6mm bolts and washers. (*Caution: over tightening may distort the cold air dam!*)



9. Slide the factory MAF meter onto the black plastic filter adapter. (*Note: factory clamp / rubber bushing must be in place on the inlet to the MAF meter.*)



10. Install the GM coupler provided onto the Airaid Intake Tube

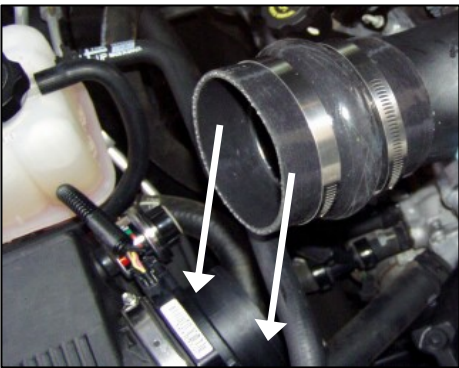

11. Install the hump hose provided onto the Airaid Intake Tube and the MAF with the supplied hose clamps. (*Hint: slide the hump hose all the way onto the end of the tube.*)

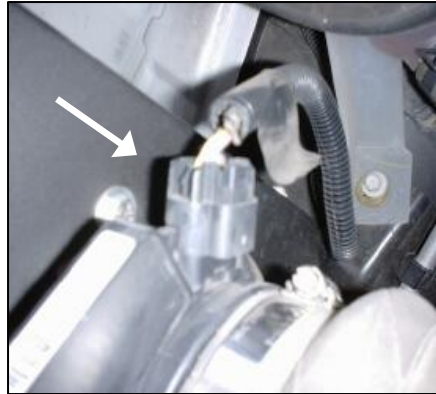

12. Reconnect the plug to the MAF sensor.

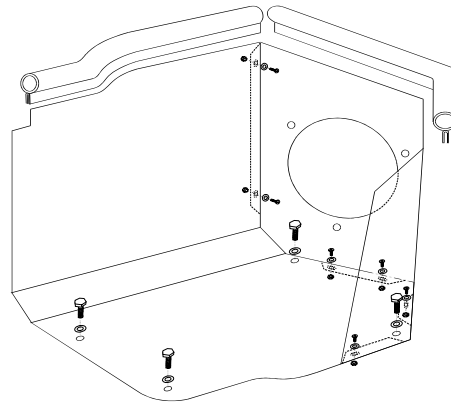

13. Press supplied weather stripping along the top edges of the Airaid cold air dam; assure that it is fully seated along the edges. (*Hint: Begin at a corner and work toward the ends.*)



14. Mount the Airaid Premium Air Filter onto the black plastic filter adapter and tighten hose clamp.

- 15. Check for any foreign objects or debris in the intake path.
- 16. Double check your work to be certain that all nuts, bolts, and clamps are securely fastened.
- 17. Reconnect the negative battery cable.

Note: Provisions have been made to mount the factory filter minder. A 17mm hole must be drilled on the back side of the tube. A circular impression on the rear of the tube indicates the correct location for the hole. Use the factory grommet to mount the filter minder.

Before



After!





Don't Forget Your AIRAID Filter Tune-Up Kit!



P/N 790-550



Instructions Revision
Date: 08/14/06