

AIR AID®

INTAKE SYSTEMS

Installation Instructions
Part Number 200-185
2005 Chevy 1500 Series Trucks/
2005-07 GMC "Classic" Trucks/
2005-06 GM Full Size SUVs
W/ 4.8L, 5.3L, 6.0L Engines W/
Electric Cooling Fan &
Low Profile Hood

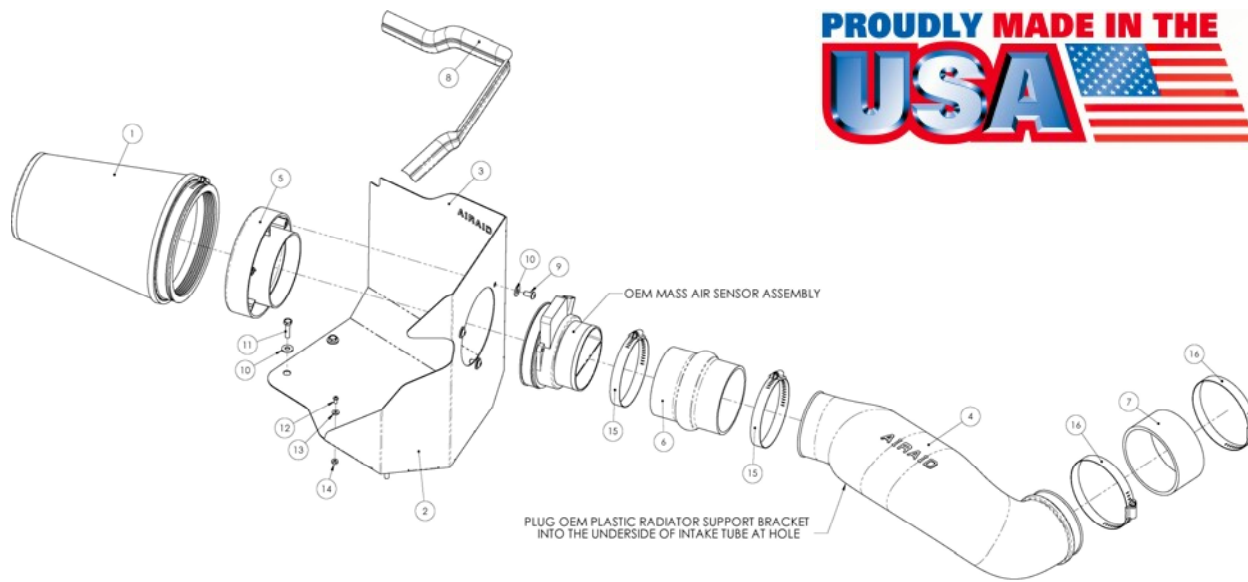

Packing List:

#1	700-469	Airaid Premium Filter	1
#2	KIT1121MAFDAC	MAF Panel Coated	1
#3	KIT1121RRDAMC	Rear Air Dam Coated	1
#4	KIT919T	Modular Intake Tube	1
#5	KIT112MAFADA	Black MAF Adapter	1
#6	KITHUMPS02	Silicone Hump Hose	1
#7	KITCOUPLER10	Silicone Coupler	1
#8	KITWSTRIP02	Weather Strip 19 1/2"	1
	KIT185HP	Hardware & Instructions	1
#9	KIT15DHC3050	1/4"-20x1/2" SS Button Head	3
#10	KIT09FWZ019	1/4" Flat Washer	7
#11	KIT60C250HCS	M6-1x25 Hex Bolt	4
#12	KIT6C31MXPPZ	6-32x 5/16" Screw	5
#13	KIT6NWSAPZ	#6 Flat Washer	5
#14	KIT6CNKEPZ	6-32 Keps Nut	5
#15	KITHS56	#56 Hose Clamp	2
#16	KITHS60	#60 Hose Clamp	2

Tools Required For Installation:

5/16", 10mm Sockets
 Ratchet & Extension
 Flat Screwdriver
 5/32" Allen Wrench



1. Disconnect negative battery cable.
 With a 5/16" socket, remove one bolt on the top of the beauty cover. Set the bolt and the cover aside for re-installation later.

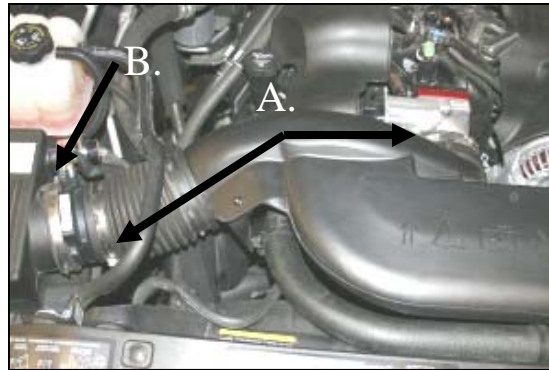

2. A.) Loosen the hose clamps on both ends of the factory intake tube. **B.)** Next loosen the hose clamp on the Mass Air Flow sensor where it clamps on the factory airbox.



3. With a screwdriver, pry the factory tube away from the plastic clamp on the radiator hose, and remove the tube.



4. Without disconnecting the electrical connector, remove the Mass Air Flow sensor from the factory airbox, and set it aside.



5. Grab the factory airbox and rock it back and forth, and remove it from the vehicle. It is only held in by grommets, no bolts.

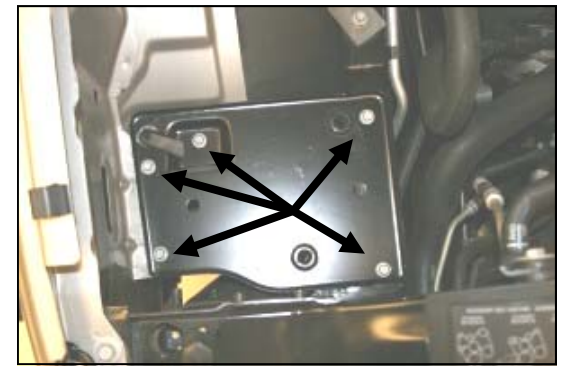

6. Remove 5 bolts and remove the factory airbox mounting plate.



7. Assemble the two Cool Air Dam panels (#2) and (#3) using the five supplied screws (#12), washers (#13), and nuts (#14), as shown.

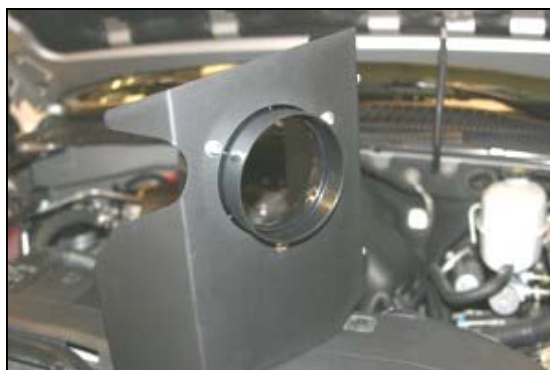

8. Install the filter adapter (#5) into the CAD using three button head bolts (#9), and washers (#10).



9. Install the assembled CAD in place of the factory airbox using four bolts (#11) and washers (#10). Do not over tighten the bolts.



10. Re-install the Mass Air Flow sensor onto the filter adapter, and tighten the hose clamp. Make sure the rectangle area where the wiring connects is pointing straight up.



11. Install the hump hose (#6) on the Mass Air Flow sensor with two #56 hose clamps (#15). Next install the coupler (#7) on the throttle body with two #60 hose clamps (#16).



12. Install the Modular Intake Tube into the hump hose first, and then into the throttle body. Adjust for fit, and tighten all four hose clamps. Re-insert the plastic piece from step #3 into the hole on the bottom of the MIT.



13. Install the Airaid Premium Filter (#1) onto the filter adapter (#5), and tighten the hose clamp. Next install the weather strip (#8) onto the top of the CAD as shown. For ease of installation start at the fender, and work towards the radiator.



14. Re-install the beauty cover and bolt removed in step #1.

15. Double check your work! Make sure there is no foreign material in the intake path. Make sure all clamps, hoses, bolts, and screws are tight.

16. Reconnect the negative battery cable!

Before!



After!



Thank you for purchasing the Airaid Intake System. Contact Airaid @ (800) 498-6951 8:00 AM - 5:00 PM MST weekdays for questions regarding fit or instructions that are not clear to you. Your Airaid Intake System was carefully inspected and packaged. Check that no parts are missing, or were damaged during shipping. If any parts are missing, contact Airaid. The air filter element is protected from direct exposure to water and debris; care should be taken not to drive through deep water. WATER INGESTION IS THE DRIVERS RESPONSIBILITY! The air filter is reusable and should be cleaned using the Airaid Filter Tune-Up Kit periodically.

Don't Forget Your AIRAID Filter Tune-Up Kit!



P/N 790-551 Aerosol Spray
P/N 790-550 Squeeze Spray



Instructions Revision
Date: 09/07/06