

AIR AID®

INTAKE SYSTEMS



Installation Instructions
Part Number 200-189
2006 GMC Sierra HD
2007 GMC Sierra "Classic" HD
6.6L Duramax "LLY" or "LBZ"
Engines W/ Low Profile Hood

Packing List:

#1	700-469	Airaid Premium Filter	1
#2	KIT189MAFC	MAF Panel	1
#3	KIT1121RRDAMC	Rear Panel	1
#4	KIT187T	MAF Adapter Tube	1
#5	KITWSTRIP02	Weather Strip 20 3/4"	1
	KIT189HP	Hardware & Instructions	1
#6	KIT15DHC3050	1/4"-20x1/2" Button Head	3
#7	KIT09FWZ019	1/4" Flat Washer	7
#8	KIT15BHC3050	8-32x1/2" Button Head Screw	2
#9	KIT60C250HCS	M6-1x25 Hex Bolt	4
#10	KIT6C31MXPPZ	6-32x 5/16" Screw	5
#11	KIT6NWSAPZ	#6 Flat Washer	5
#12	KIT6CNKEPZ	6-32 Keps Nut	5
#13	KITX1011	Rubber Trim 6 1/2"	1

Tools Required For Installation:

5/16", 10mm Sockets
 Ratchet & Extension
 Phillips Screwdriver
 3/32", 5/32" Allen Wrench
 #20 Torx Bit

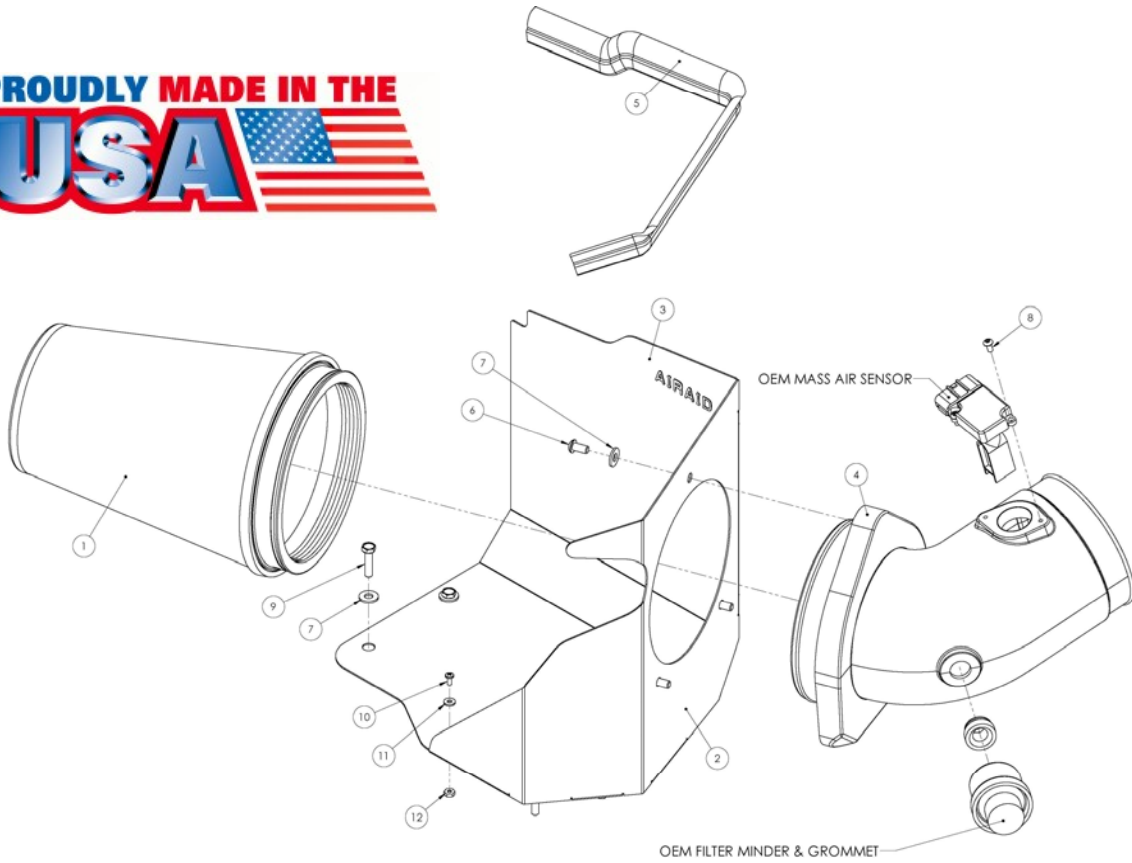

1. Disconnect the negative battery cable.
 With a 5/16" socket or flat screwdriver, loosen the hose clamp that holds the factory airbox to the flexible intake tube.



2. With a #20 Torx bit, remove 2 screws holding the Mass Air Flow sensor to the factory airbox tube.



3. Without disconnecting the wiring harness, remove the Mass Air Flow sensor from the factory airbox, and set it aside.



4. Slide the flexible intake tube off of the factory airbox and then rock the airbox back and forth to free it from the mounting grommets, then lift it straight up and remove it from the vehicle.



5. Remove the factory filter minder and grommet from the factory airbox. Save them for later use.



6. With a 10mm socket, remove 5 bolts from the factory airbox mounting plate. Remove the plate from the vehicle.



7. Assemble the two Cool Air Dam panels (#2) and (#3) as shown, using the five 6-32 screws (#10), washers (#11), and nuts (#12)

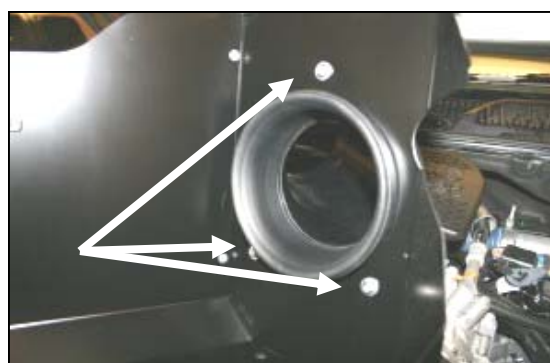

8. Install the Airaid intake tube (#4) into the Cool Air Dam using the three 1/4"-20x1/2" button head bolts (#6), and washers (#7) as shown.



9. Re-install the factory grommet and filter minder removed in step #5 into the Airaid intake tube.

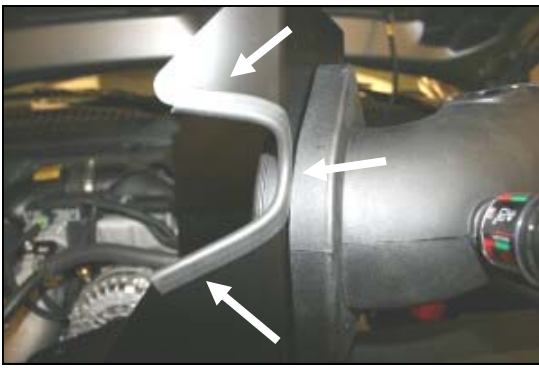

10. Install the provided rubber trim (#13) on the CAD as shown.



11. Install the assembled CAD into the vehicle where you removed the factory mounting plate in step #6. Use four bolts (#9), and washers (#7) to secure the CAD. Do not over tighten the bolts.



12. Re-position the factory intake tube onto the Airaid tube, and tighten the hose clamp. Next re-install the Mass Air Flow sensor into the Airaid tube using the two provided Button Head screws (#8). Do not use the factory screws! Do not over tighten!



13. Install the Airaid Premium Filter (#1) onto the Airaid intake tube (#4), and tighten the hose clamp. Now install the provided weather strip (#5) on the top of the CAD. For ease of installation, start near the fender and work your way towards the radiator.

14. Double check your work!

Make sure there is no foreign material in the intake path. Make sure all clamps, hoses, bolts, and screws are tight.

15. Reconnect the negative battery cable!

Thank you for purchasing the Airaid Intake System. Contact Airaid @ (800) 498-6951 8:00 AM - 5:00 PM MST weekdays for questions regarding fit or instructions that are not clear to you. Your Airaid Intake System was carefully inspected and packaged. Check that no parts are missing, or were damaged during shipping. If any parts are missing, contact Airaid. The air filter element is protected from direct exposure to water and debris; care should be taken not to drive through deep water. **WATER INGESTION IS THE DRIVERS RESPONSIBILITY!** The air filter is reusable and should be cleaned using the Airaid Filter Tune-Up Kit periodically.

Before!



After!



Don't Forget Your AIRAID Filter Tune-Up Kit!



**P/N 790-551 Aerosol Spray
P/N 790-550 Squeeze Spray**

Instructions Revision
Date: 09/07/06