

# AIRRAID®

## INTAKE SYSTEMS

**Installation Instructions**  
**Part Number 300-165**  
**2005-08 Dodge Dakota**  
**2006-07 Mitsubishi Raider**  
**3.7L, 4.7L V-8**

### Packing List:

#1	720-440	Airaid Premium Filter	1
#2	KIT165DC	Quick Fit Panel	1
#3	KITWSTRIP02	Weather Strip 28"	1
	KIT175HP	Hardware & Instructions	1
#4	KITSNP24GHS	#24 Speed clamp	1

### Tools Required For Installation:

5/16" Nut Driver  
 Flat Blade Screwdriver

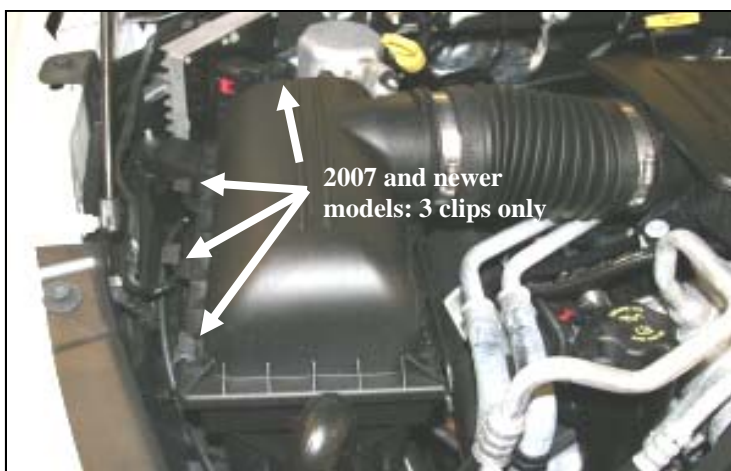
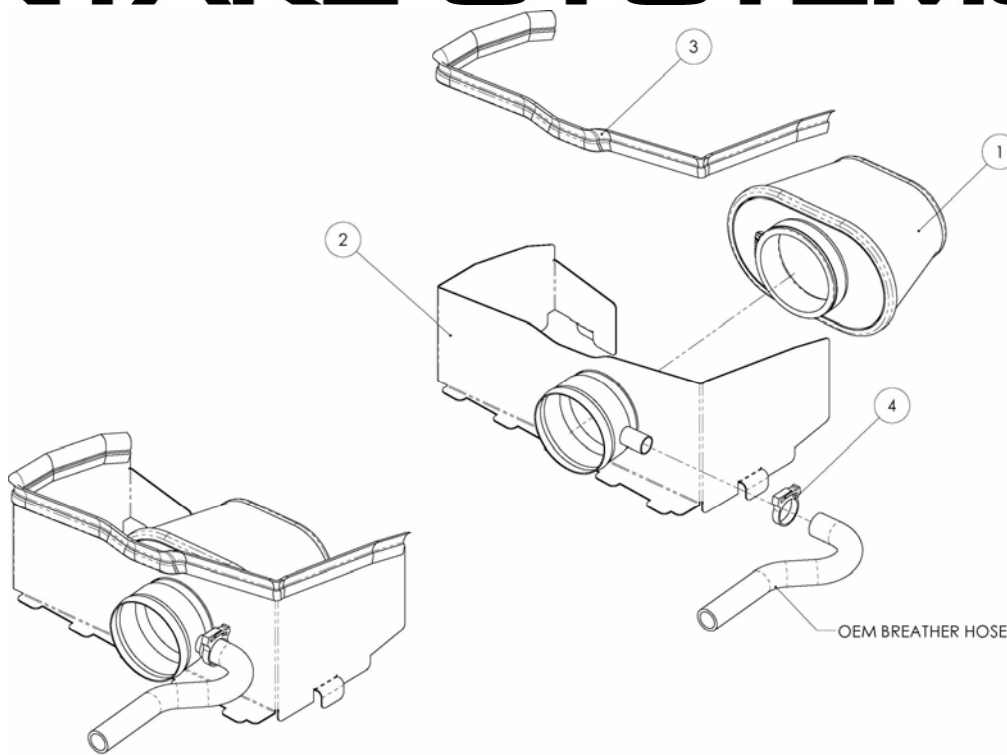

**1. Disconnect the negative battery cable.**  
 Unlatch the four clips (three on 2007 and newer models) on the factory airbox.



**2. A.) Loosen the hose clamp on the factory airbox lid.**  
**B.) Disconnect the breather hose from the factory airbox lid.**



**3. Remove the factory airbox lid and air filter from the airbox base.**



**4. 2007 and newer models only:** A.) Using a flat blade screwdriver, gently pry and remove one factory clip from the passenger side rear of the airbox base. (see arrow above) B.) Re-install the clip onto the rear of the factory airbox base (see arrow above).



**5. Slip the five tabs of the Quick fit panel (#2) through the slots on the airbox base. Adjust the panel for fit, then re-latch two of the factory clips onto the panel.**



**6. Slide the factory intake tube onto the Quick Fit Panel and tighten the hose clamp.**



7. Re-connect the factory breather hose onto the Quick Fit Panel and secure with the #24 speed clamp (#4) as shown.

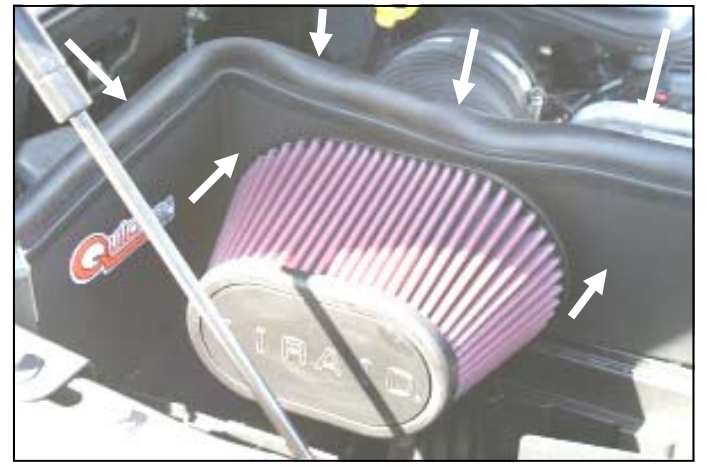

8. Install the Airaid Premium Filter (#1) onto the Quick Fit Panel as shown, and tighten the clamp. Install the weather strip (#3) onto the top of the Quick Fit Panel as shown. (*Hint: Start at one end and work towards the other.*)

**9. Double check your work!**

Make sure there is no foreign material in the intake path. Make sure all clamps, hoses, bolts, and screws are tight.

**10. Reconnect the negative battery cable!**

Thank you for purchasing the Airaid Intake System. Contact Airaid @ (800) 498-6951 8:00 AM - 5:00 PM MST weekdays for questions regarding fit or instructions that are not clear to you. Your Airaid Intake System was carefully inspected and packaged. Check that no parts are missing, or were damaged during shipping. If any parts are missing, contact Airaid. The air filter element is protected from direct exposure to water and debris; care should be taken not to drive through deep water. WATER INGESTION IS THE DRIVERS RESPONSIBILITY! The air filter is reusable and should be cleaned using the Airaid Filter Tune-Up Kit periodically.

*Before!*



*After!*



**Don't Forget Your AIRAID Filter Tune-Up Kit!**



P/N 790-551 Aerosol Spray  
P/N 790-550 Squeeze Spray



Instructions Revision  
Date: 08/27/07