

# AIR AID<sup>®</sup>

## INTAKE SYSTEMS

**Installation Instructions**  
**Part Number 300-175**  
**2005-08 Dodge Dakota**  
**2006-07 Mitsubishi Raider**  
**4.7L V-8**

### Packing List:

#1	720-440	Airaid Premium Filter	1
#2	KIT165DC	Quick Fit Panel	1
#3	KIT965T	Airaid Intake Tube	1
#4	KITRDCR01	Reducing Coupler	1
#5	KITHUMPHS02	Urethane Hump Hose	1
#6	KITWSTRIP02	Weather Strip 27 1/2"	1
	KIT175HP	Hardware & Instructions	1
#7	KITHS48	#48 Hose Clamp	1
#8	KITHS52	#52 Hose Clamp	1
#9	KITHS60	#60 Hose Clamp	2
#10	KITSNP24GHS	#24 Speed clamp	1
#11	KITGRMT03	Grommet	1

### Tools Required For Installation:

5/16" & 10mm Sockets  
 Ratchet & Extension

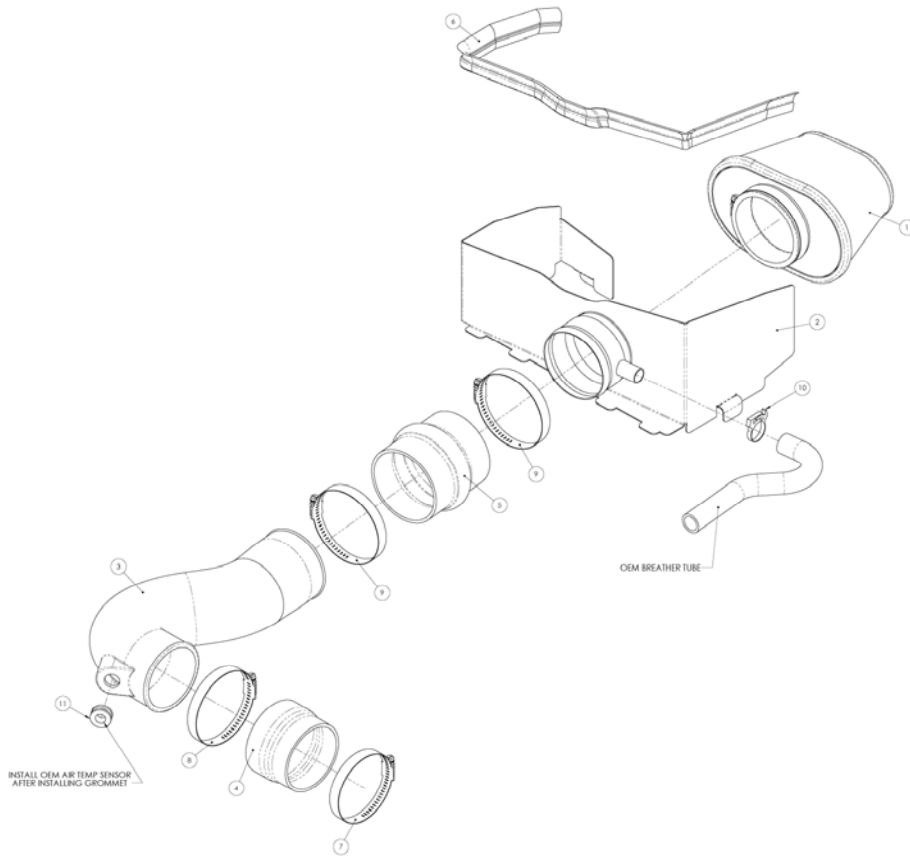

**1. Disconnect the negative battery cable.**  
 Unlatch the four clips (three on 2007 models) on the factory airbox.



**2. A.)** Loosen the hose clamp on the resonator end of the intake tube. **B.)** Disconnect the breather hose from the factory airbox lid.



**3. Remove the factory airbox lid and tube. Remove the factory air filter from the factory airbox base.**

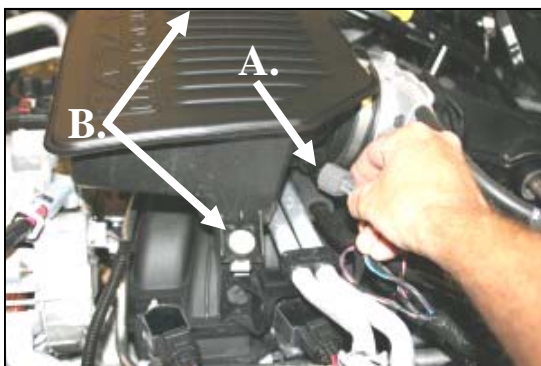

**4. A.)** Disconnect the Air Intake Temperature (AIT) sensor wiring harness. **B.)** Using a 10mm socket, remove the two bolts (one on each side) that hold the resonator to the intake manifold, and then remove the resonator.



**5. 2007 Models only:** **A.)** Using a flat blade screwdriver, gently pry and remove one factory clip from the passenger side rear of the airbox base. (see arrow above) **B.)** Re-install the clip onto the rear of the factory airbox base (see arrow above).



**6. Slip the five tabs of the Quick fit panel (#2) through the slots on the airbox base. Adjust the panel for fit, then re-latch two of the factory clips onto the panel.**



**7. Re-connect the factory breather hose onto the Quick Fit Panel and secure with the #24 speed clamp (#10) as shown.**



**8. Install the grommet (#11) into the Airaid Intake Tube (#3).**



**9. Carefully twist and remove the AIT sensor from the factory resonator.**



**10.** Carefully install the AIT sensor into the grommet in the Airaid Intake Tube. Make sure it goes all the way in.

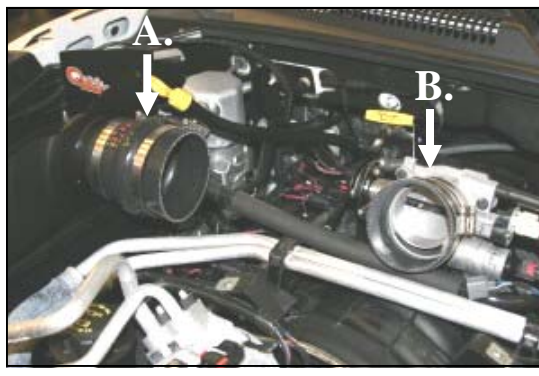

**11.** A.) Install the urethane hump hose (#5) and two #60 hose clamps (#9) onto the Quick fit Panel.  
B.) Install the reducing coupler (#4) onto the throttle body using one #52 hose clamp (#8) on the tube side, and one #48 hose clamp (#7) on the throttle body side. (Leave the clamps loose for now.)

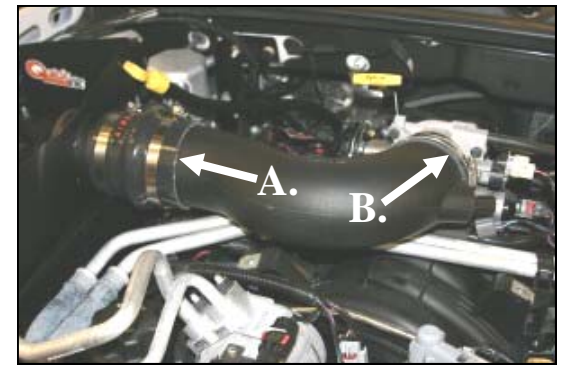

**12.** A.) Slide the Airaid Intake Tube into the hump hose first.  
B.) Slide the other end of the Airaid intake tube into the reducing coupler on the throttle body. Adjust the tube for fit, and tighten the clamps.



**13.** Reconnect the AIT sensor wiring harness to the sensor.

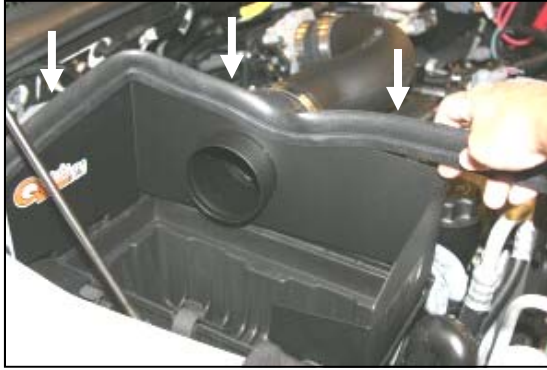

**14.** Install the weather strip (#6) onto the top of the Quick Fit Panel as shown. (*Hint: Start at one end and work towards the other.*)



**15.** Install the Airaid Premium Filter (#1) onto the Quick Fit Panel as shown, and tighten the clamp.

**16. Double check your work!**

Make sure there is no foreign material in the intake path. Make sure all clamps, hoses, bolts, and screws are tight.

**17. Reconnect the negative battery cable!**

Thank you for purchasing the Airaid Intake System. Contact Airaid @ (800) 498-6951 8:00 AM - 5:00 PM MST weekdays for questions regarding fit or instructions that are not clear to you. Your Airaid Intake System was carefully inspected and packaged. Check that no parts are missing, or were damaged during shipping. If any parts are missing, contact Airaid. The air filter element is protected from direct exposure to water and debris; care should be taken not to drive through deep water. WATER INGESTION IS THE DRIVERS RESPONSIBILITY! The air filter is reusable and should be cleaned using the Airaid Filter Tune-Up Kit periodically.

*Before!*



*After!*



**Don't Forget Your AIRAID Filter Tune-Up Kit!**



P/N 790-551 Aerosol Spray  
P/N 790-550 Squeeze Spray



Instructions Revision  
Date: 08/27/07